

Enzyme rhythms in model four_cycle.speedy - spontaneous oscillations

Model name: four_cycle

o Optimisation problem

- Protein turnover time $1 \text{ s} = 0.0167 \text{ min}$
- Perturbed parameter(s) : x1
- Perturbation frequency $f : 0.444/\text{s}$ (period 2.25 s)
- Scored quantity: v3
- Fitness-averaged fitness
- No posttranslational rhythms allowed
- Standard frequency considered $f : 0.444/\text{s}$ (period 2.25 s)

o Model properties:

- inactive_enzymes: 0
- balanced_reference_state: 1
- consider_external_rhythm: 1
- adaptive_rhythm: 0
- spontaneous_rhythm: 1
- spontaneous_rhythm_at_omega: 1
- has_spontaneous_rhythm_and_inactive_enzymes: 0

o Beneficial autonomous oscillation found

- Maximum principal synergy found (in tested range) at frequency $f = 0.631/\text{s}$ (period 1.58 s)
- Maximum fitness found (in tested range) at frequency $f = 0.447/\text{s}$ (period 2.24 s)

o Fitness changes after external perturbation at frequency $f = 0.444/\text{s}$

- Change by perturbation alone (xx): $-2.22e-08$

o autonomous oscillations?

- Maximally autonomous oscillations (in tested range) at $f = 0.631$, principal synergy 0.0141
- Beneficial autonomous oscillations found at frequency $f = 0.444/\text{s}$ (principal synergy = 0.0114)
- Predicted fitness change (autonomous, 2nd order, amplitude below 1/2 of mean) at frequency $f = 0.444$: 0.00123
- Predicted maximal fitness change (autonomous, numeric opt, full amplitude constraints) at frequency $f = 0.447$: $5.33e-06$

WARNING: an external rhythm is given and a autonomous rhythm has been found

o Numerical calculation (responsive, $f = 0.444$)

- Fitness change (fitness-averaged): $-5.36e-05$
- Fitness change (state-averaged): $-5.36e-05$

o Numerical calculation (autonomous rhythm, amplitude below 1/2 of mean, $f = 0.444$)

- Fitness change (fitness-averaged) : $3.87e-05$
- Fitness change (state-averaged): $3.91e-05$

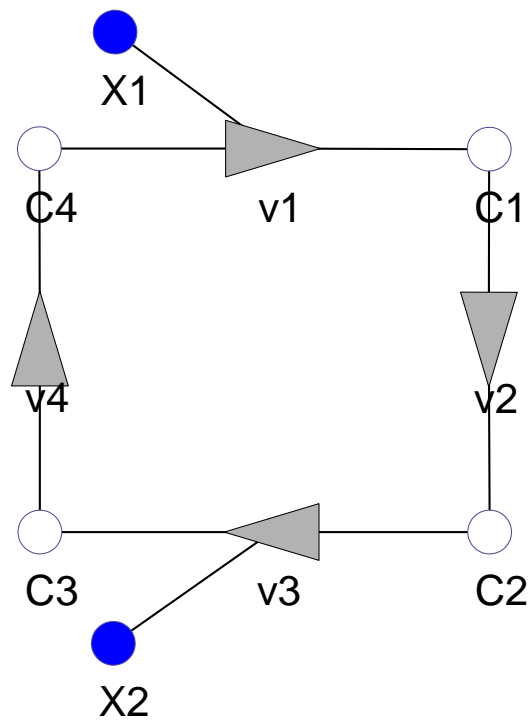
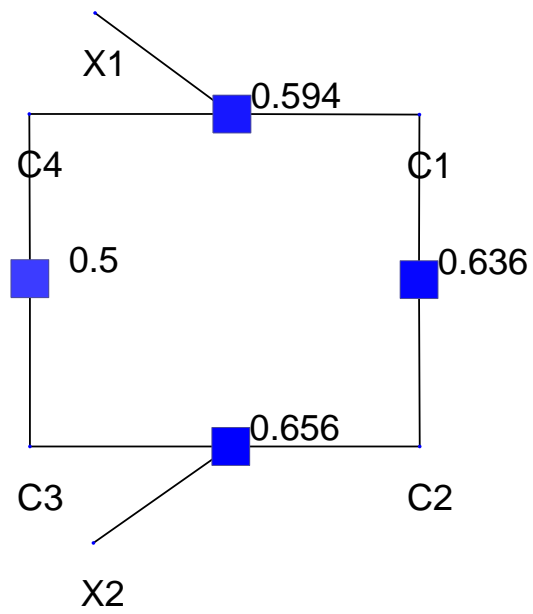
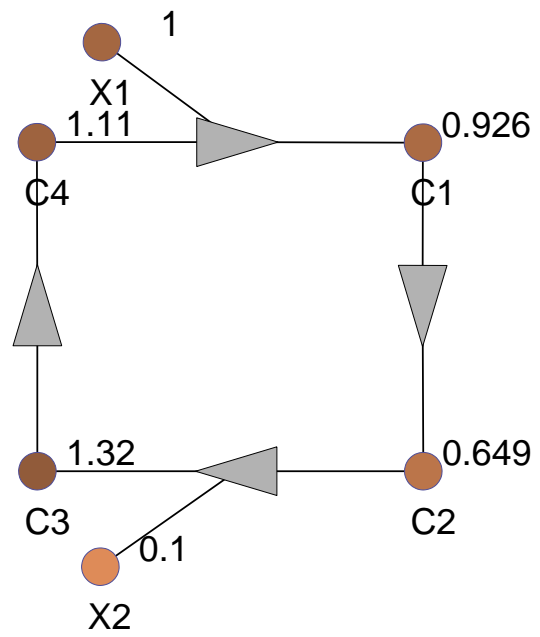

Figure 1: Network and reference flux

Enzyme levels (reference state)



Metabolite levels (reference state)



Mean enzyme levels

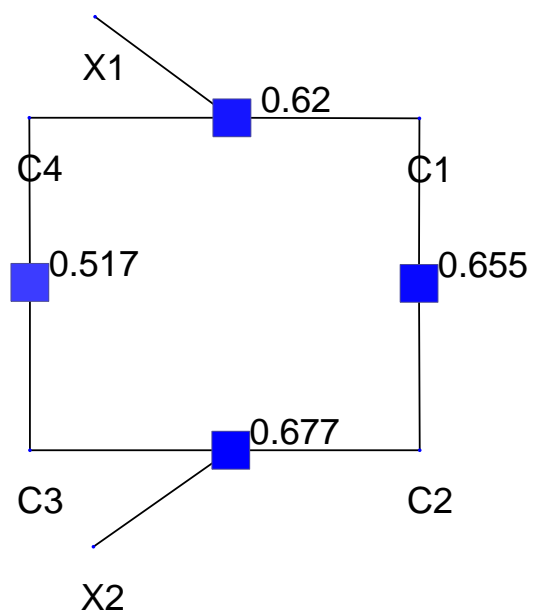

Mean metabolite levels

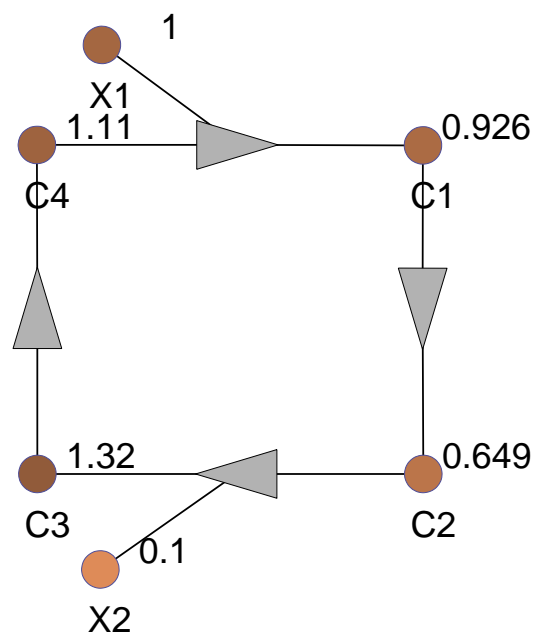

Figure 2: Reference state (top) and mean state during oscillation (bottom).

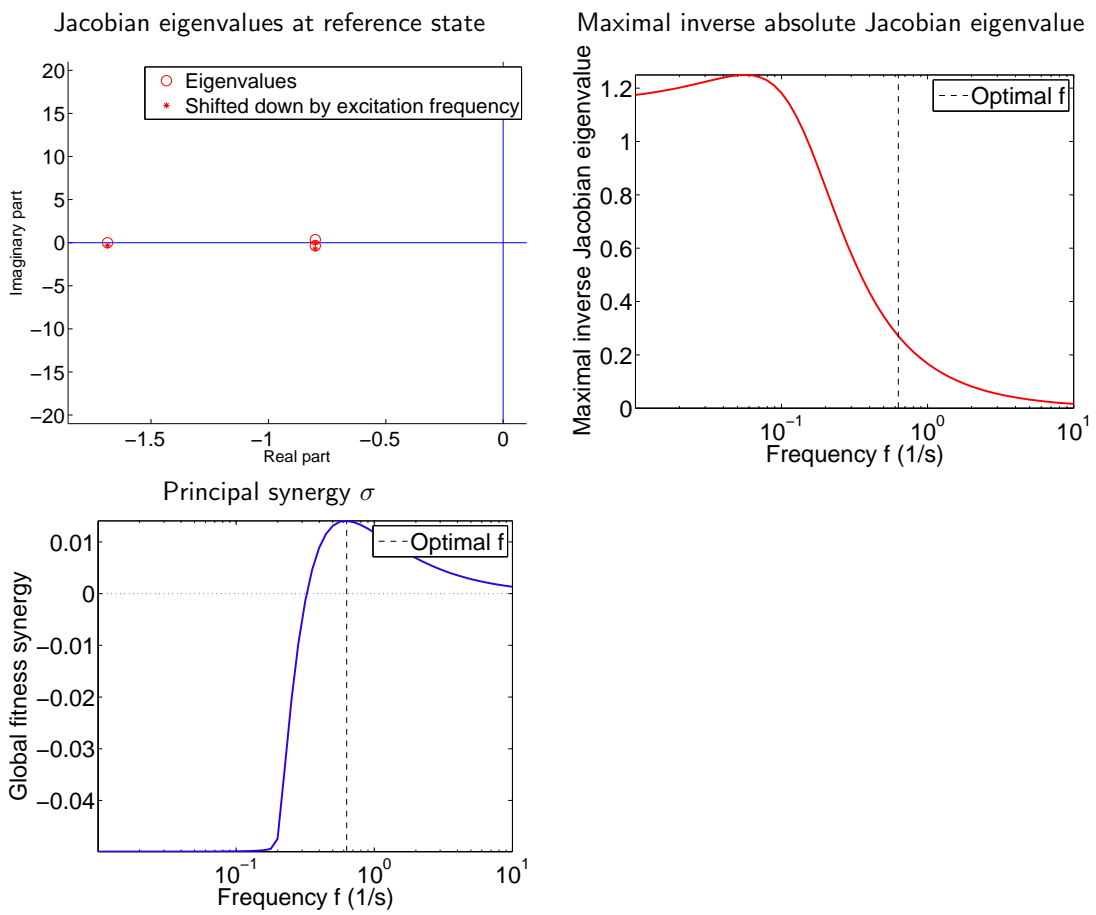
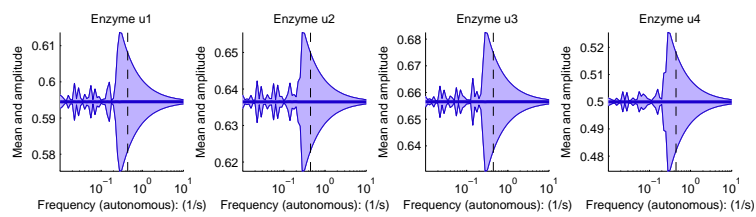
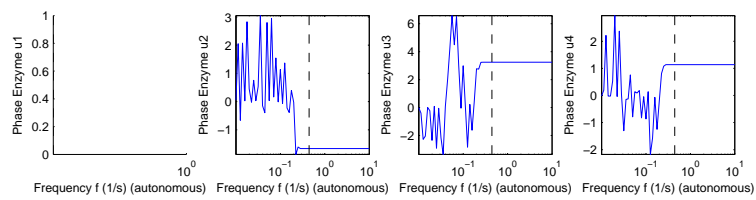

Figure 3: Control analysis: fitness curvatures. Left: Frequency-dependent fitness curvature eigenvalues. Right: relative sizes and phases of the individual enzyme levels (components of the leading fitness curvature eigenvector).

Protein level and enzyme activity (mean and amplitude)



Phase angles $[0, 2\pi]$



Fitness change

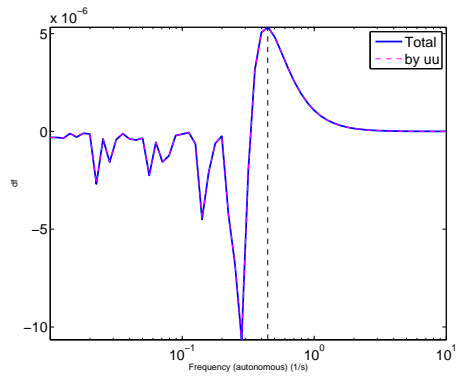

Figure 4: Self-promoting oscillations. Left: amplitudes of protein levels (blue) and modification (grey). Right: phase shifts.

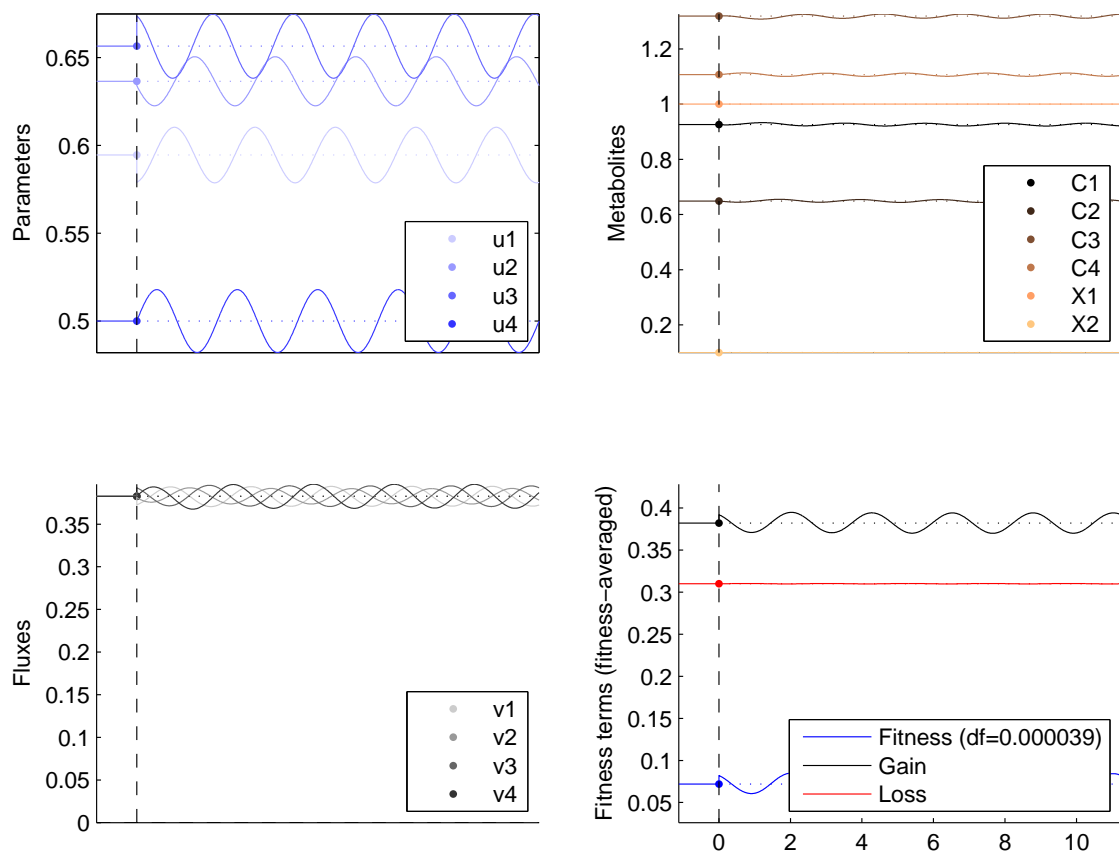

Figure 5: Numerical calculations: spontaneous oscillations. Perturbation frequency see first page.

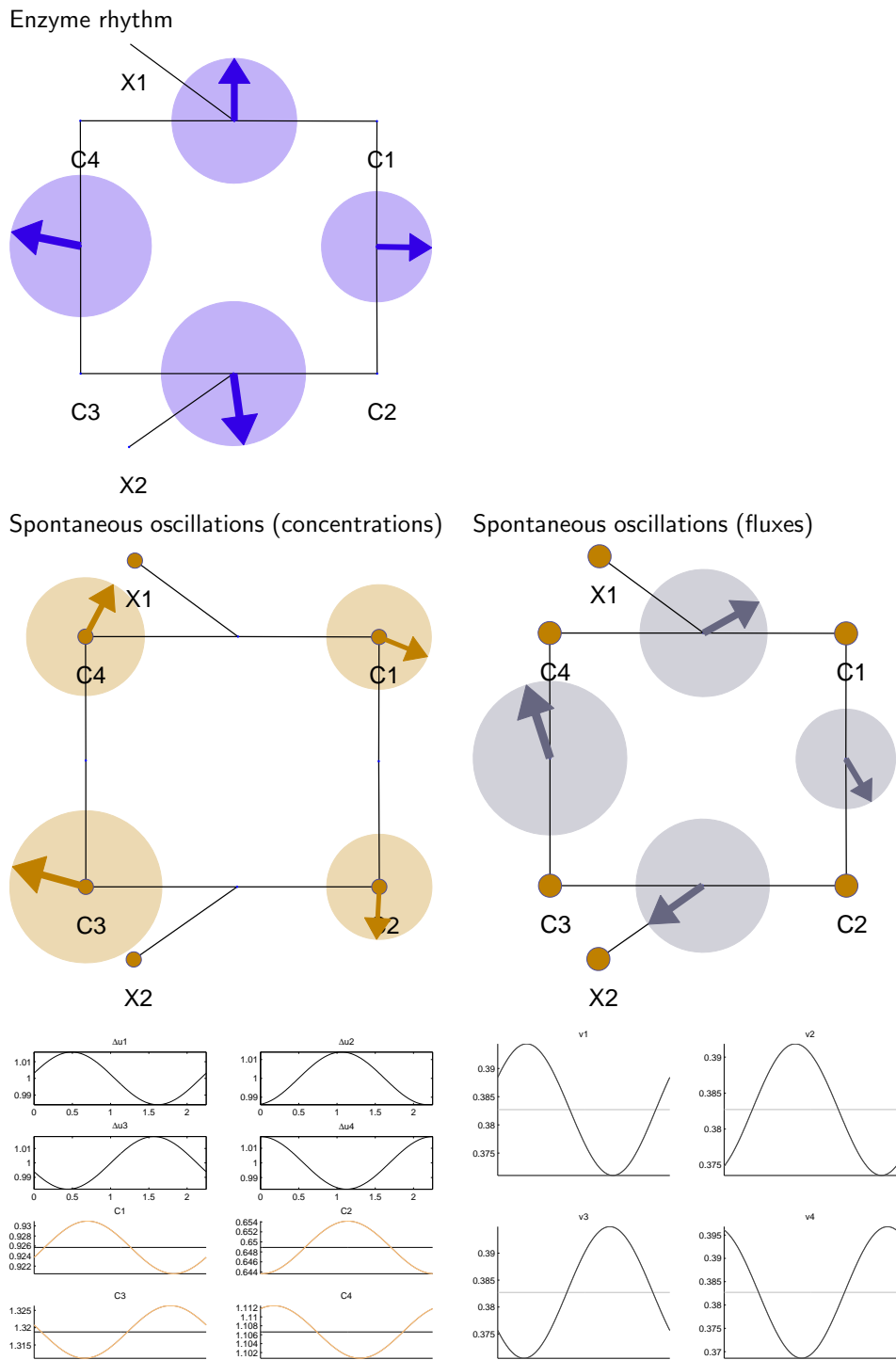

Figure 6: Spontaneous oscillations (local expansion; arrows: absolute changes). Perturbation frequency see first page.

Spontaneous oscillations

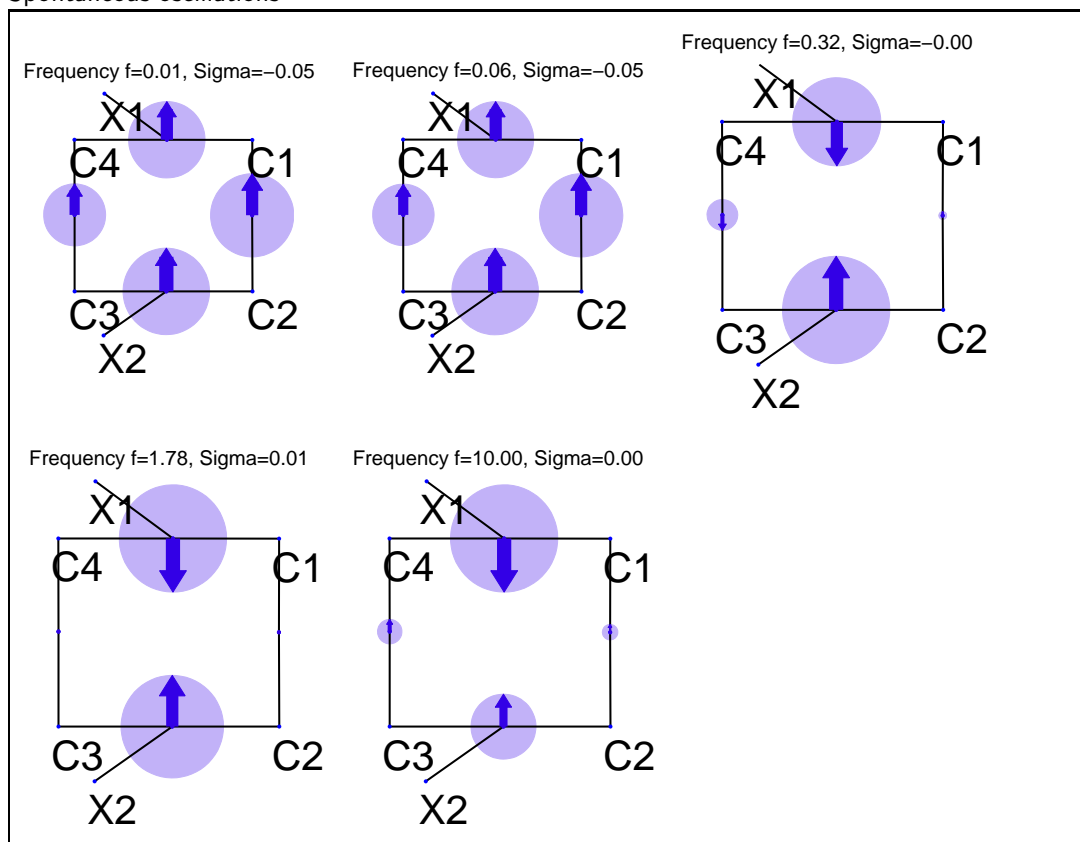

Figure 7: Spontaneous oscillations (or tendencies towards them) for various circular frequencies ω . If the maximal fitness curvatures λ is positive, the rhythm is beneficial (local expansion; arrows: absolute changes).